

Quantity	GRID LOCATION	WORK ELEVATION
1	3-4B-C	9'-8.916"

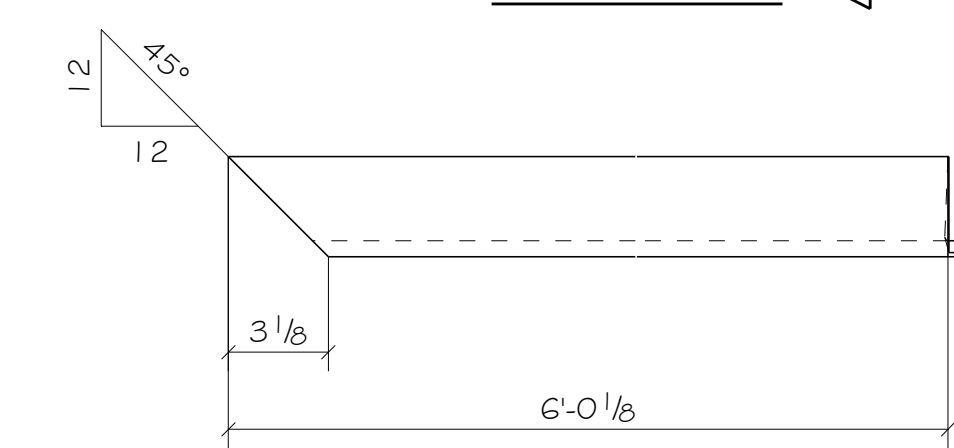
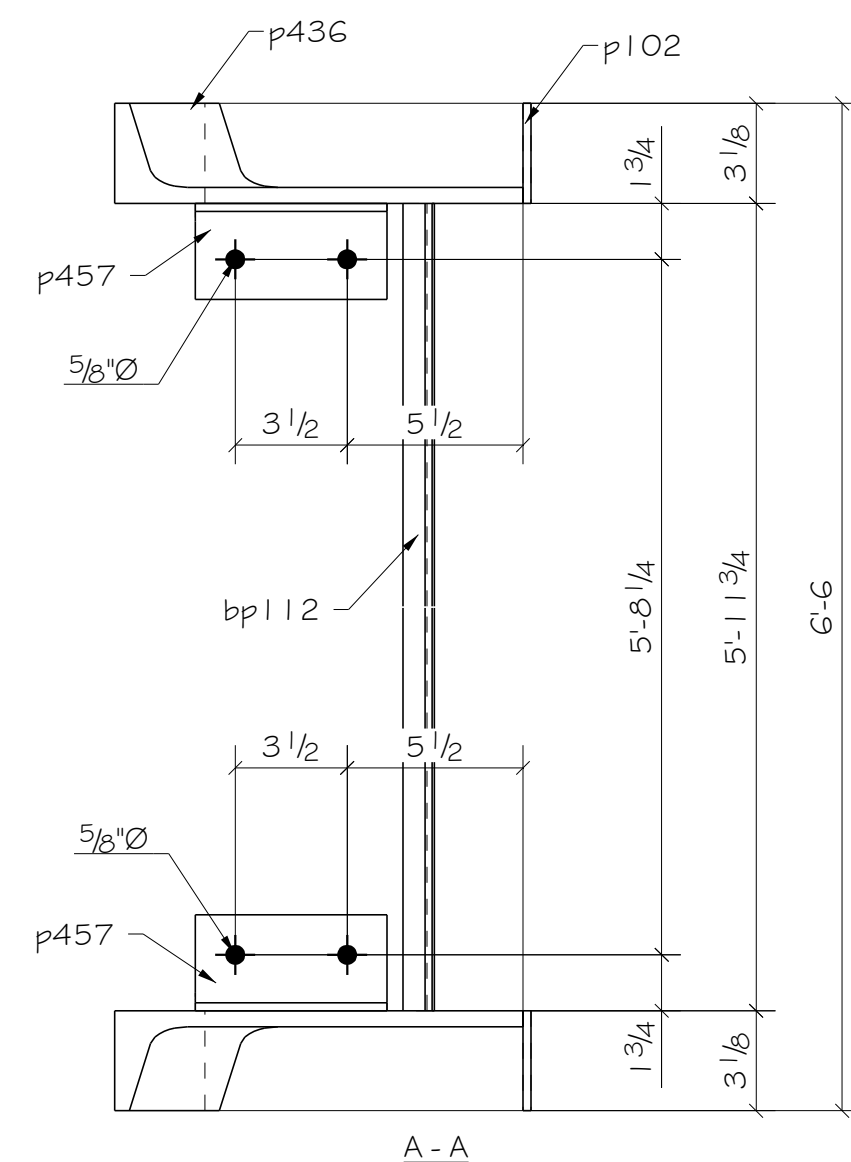
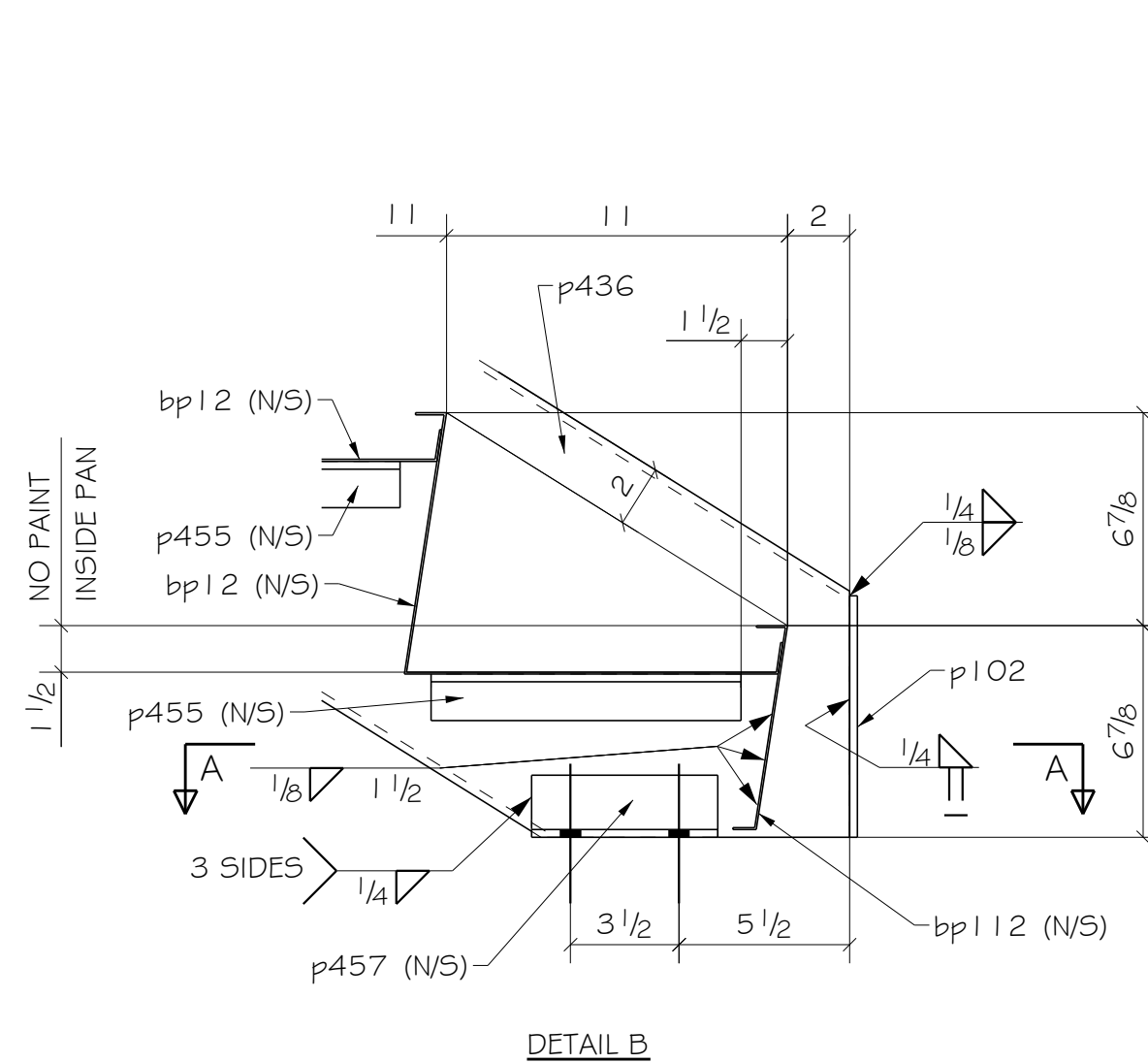
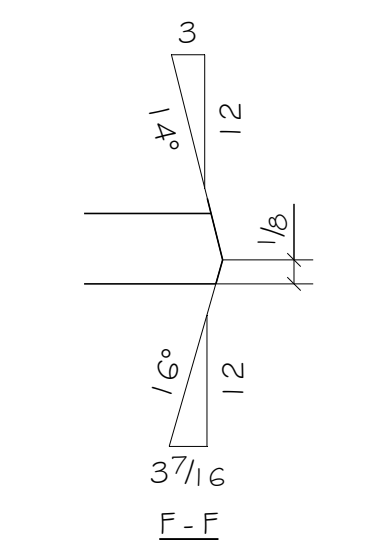
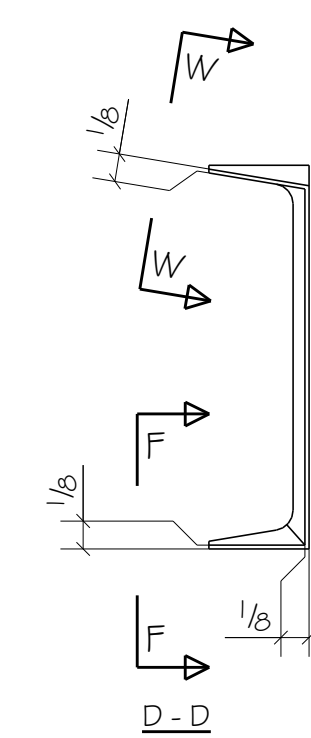
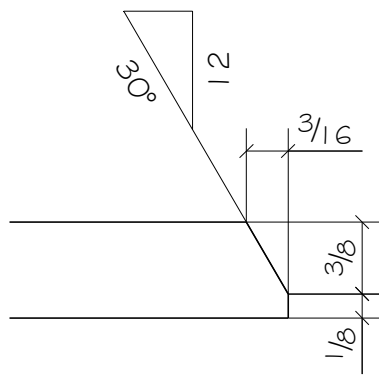
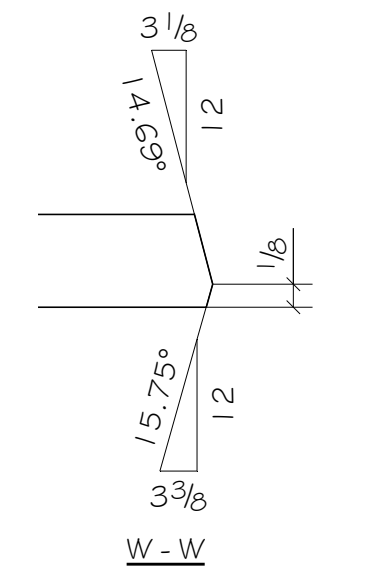
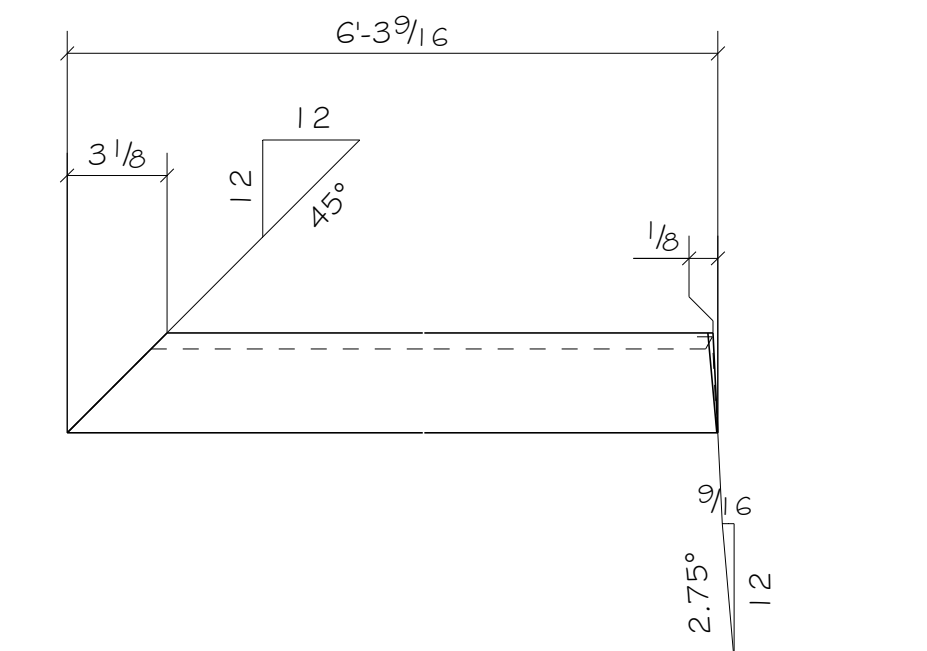
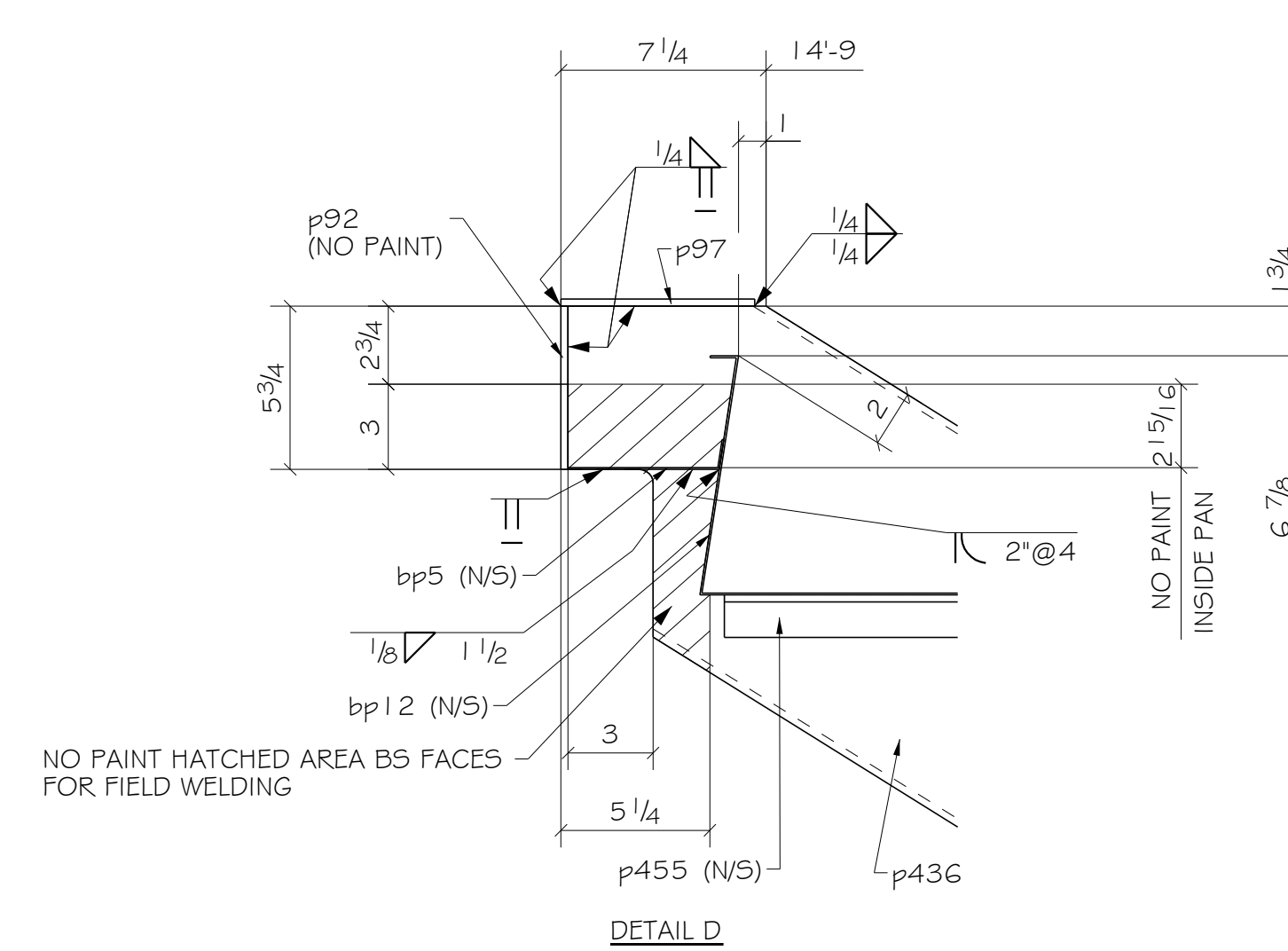
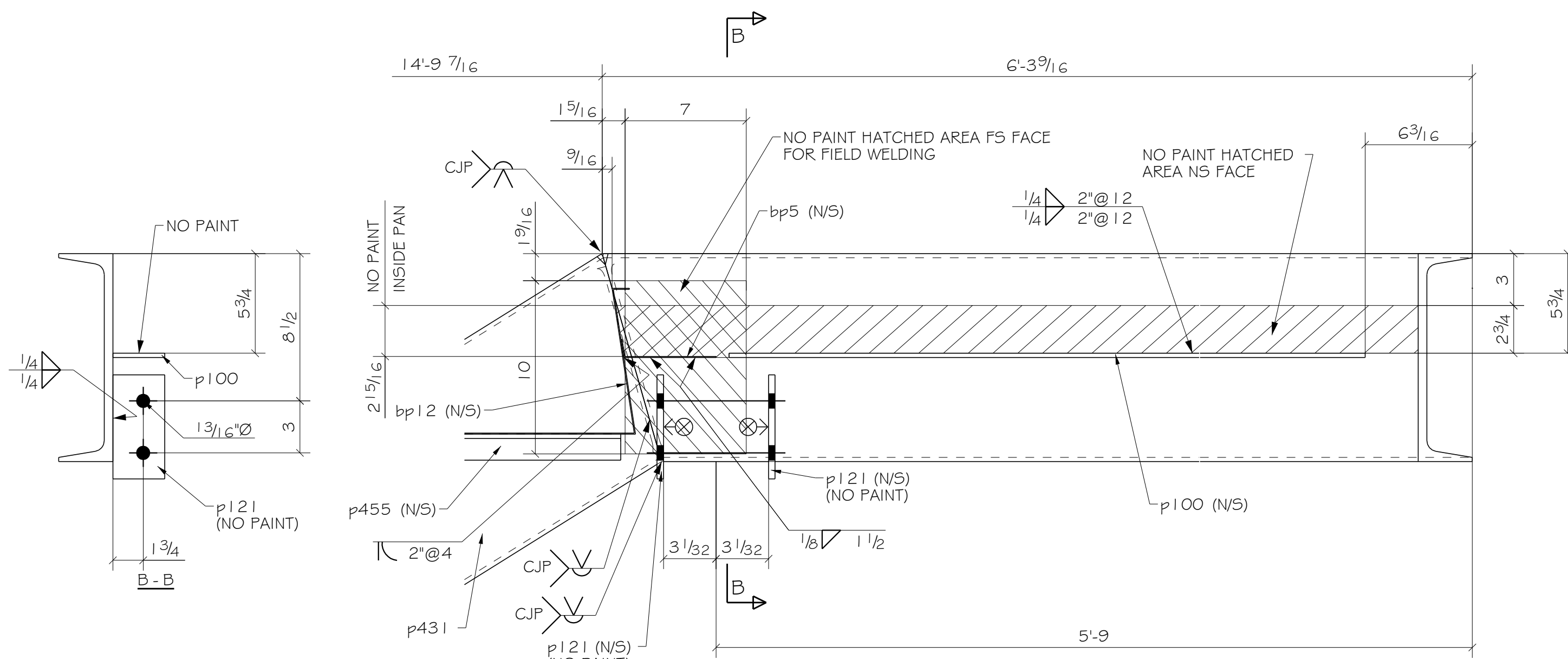
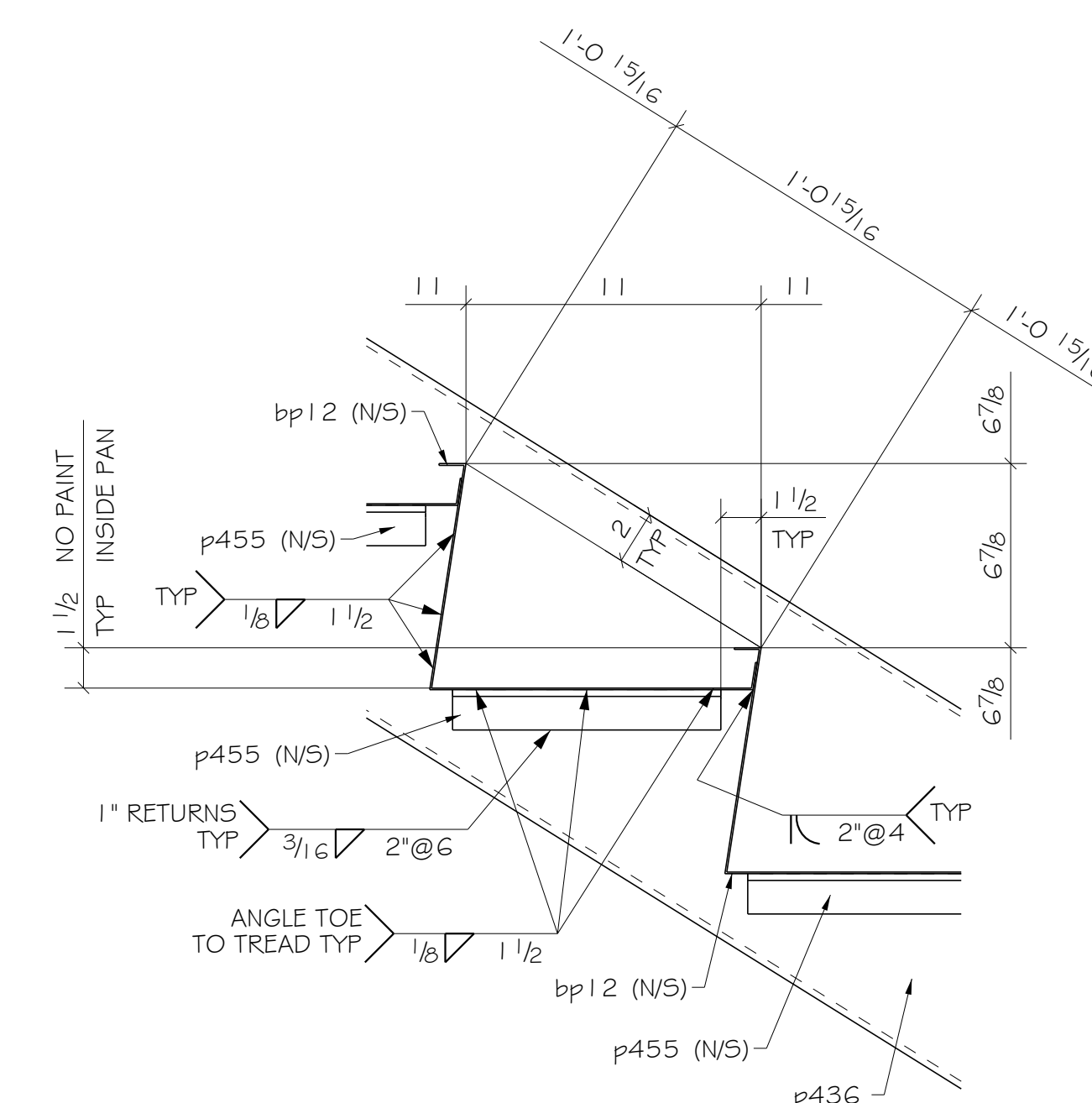
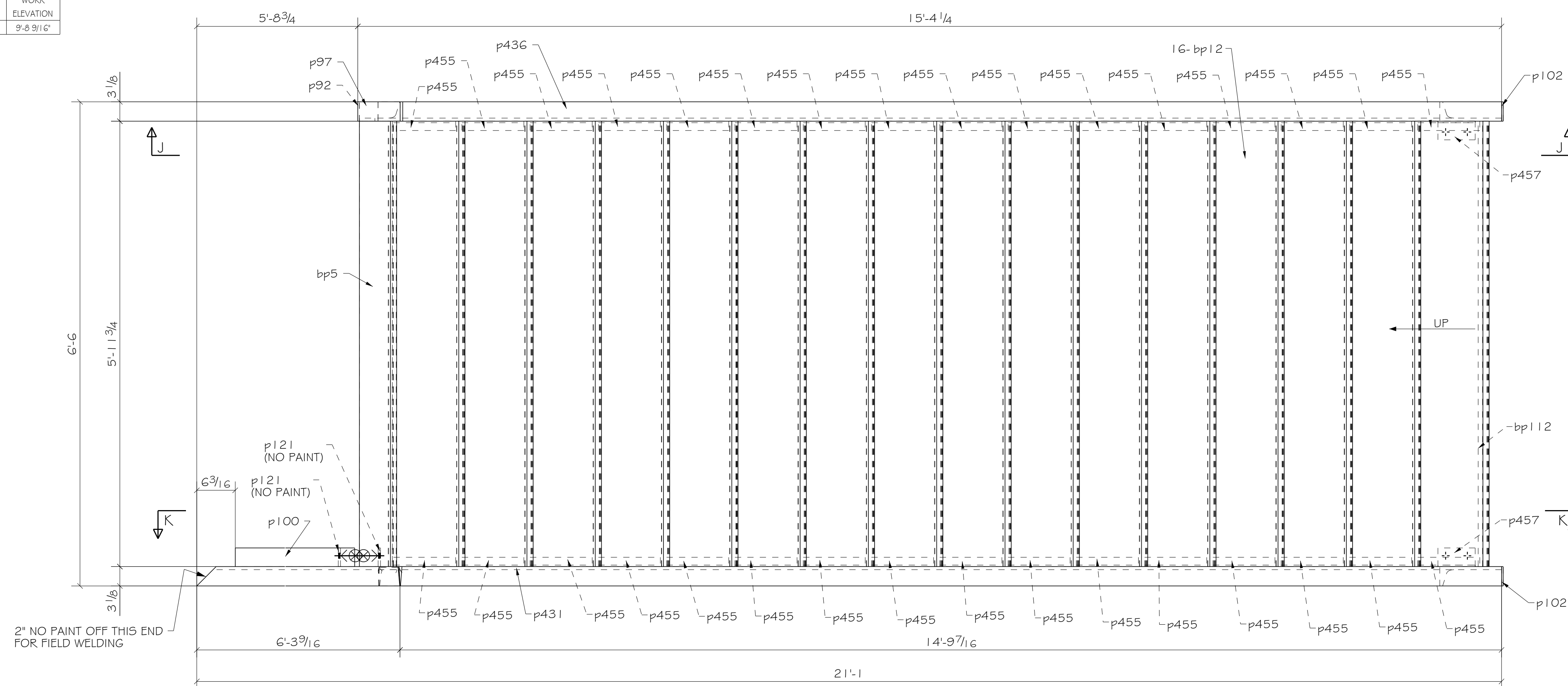

ONE - STAIR - MGG

BILL OF MATERIAL						
Quantity	Piece	Description	Length	Weight	Remarks	Steel Grade
Each	Total	Mark		Total		
1	1	MGG STAIR				A36
1	1	C12X30	6'-3 9/16"	189		
1	1	bp5	5'-11 3/4"	8	BENT	
1G	1G	bp12	14GAW22 3/16"	456	BENT	
1	1	bp12	14GAW8 1/8"	11	BENT	
1	1	p92	PL1/4X3 1/8"	1		
1	1	p97	PL1/4X3 1/8"	2		
1	1	p100	PL1/4X3	13		
2	2	p102	PL1/4X3 1/8"	3		
2	2	p121	PL3/8X3	4		
1	1	p431	C12X30	533		
1	1	p436	C12X30	547		
32	32	p455	L1-1/2X1-1/2X1/4	62		
2	2	p457	L3X2X1/4	4		
4	4	1/2" EXPANSION ANCHOR	0'-4 1/2"		FIELD NUT & WASHER	

WORK THIS SHEET WITH SHEET MGG-2

STEEL ASTM	A36	UNO	VERIFICATION OF DIMENSIONS, DETAILS AND ETC. ARE REQUESTED, WHERE INDICATED, IF EACH VERIFICATION IS NOT NOTED OTHERWISE, IT WILL BE ASSUMED TO BE CORRECT AS SHOWN.
WELDS	E70XX	UNO	
PAINT	ONE COAT SHOP PRIMER	UNO	
OPEN HOLES	AS-NOTED	UNO	

DATE	REV.	DESCRIPTION	BY
02/24/2017		FOR FABRICATION	VM
02/15/2017		FOR RE-APPROVAL PER ALL STRUCTURE ENGINEERING MARKUPS	VM
02/07/2017		FOR RE-APPROVAL	VM
11/22/2016		FOR RE-APPROVAL PER ENGINEER COMMENTS	VM
11/02/2016		FOR APPROVAL	VM